

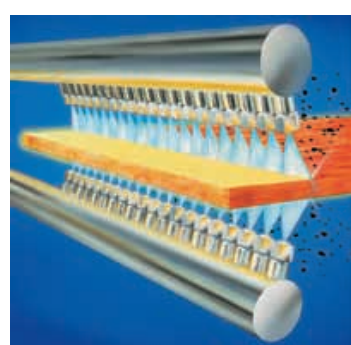

New

**MicroSCALEMASTER®
Descaling Nozzle**

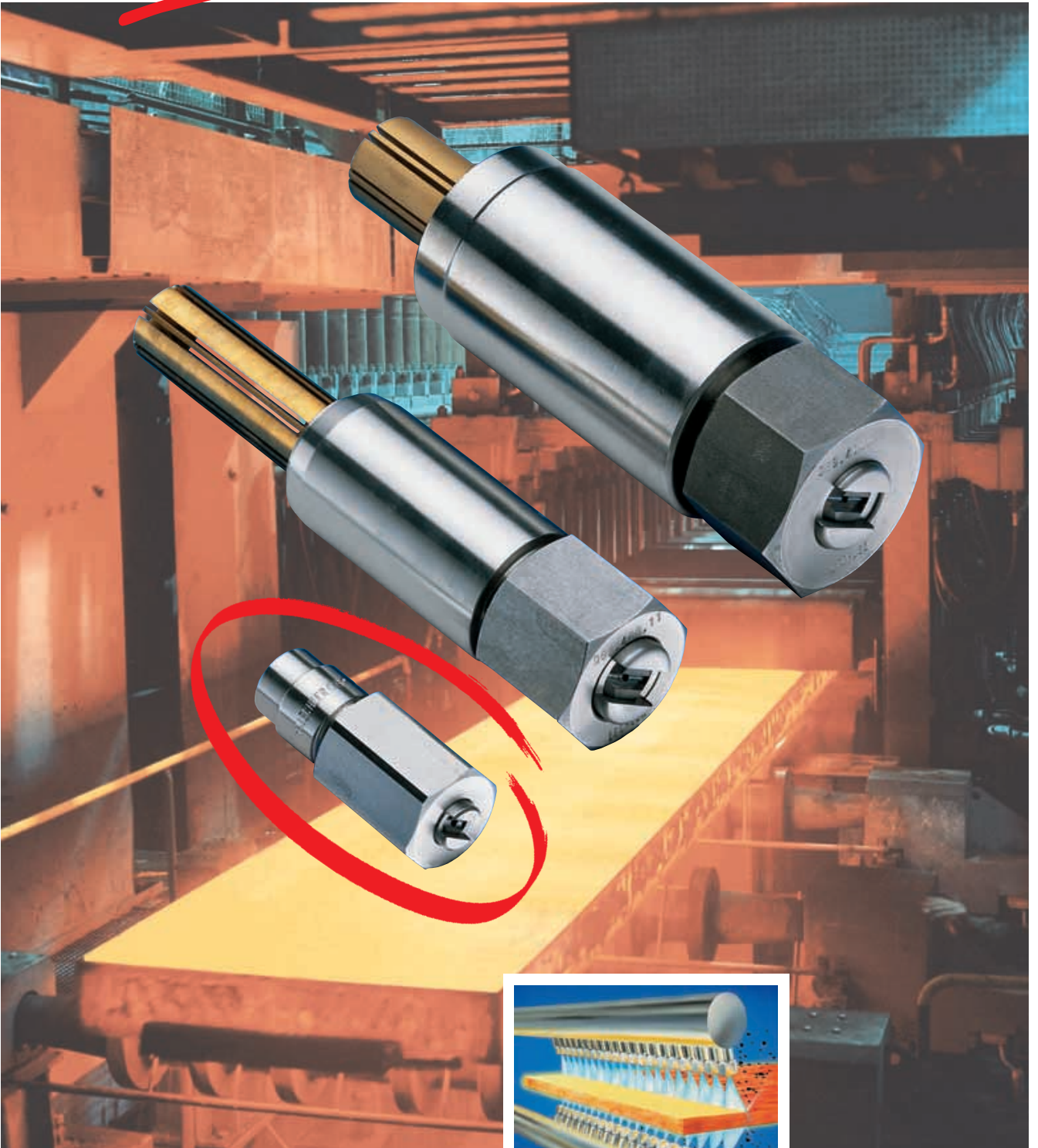

MicroSCALEMASTER® Size Comparison

The application and typical problems

During the early stages of the development of hydraulic descaling nozzles a very robust and large set of components with outer diameters well beyond 40 mm was the solution for spray heights often greater than 300 mm. Today the plant requirements changed significantly for:

- Thin slab plants where the rate of slab cooling during descaling had to be reduced.
- Descaling of sections (heavy, medium and light), rails.
- Descaling of forged products.

All these applications have in common the requirement for small outer nozzle dimensions suitable for spray heights between 50 and 100 mm. Moreover, it is desirable to keep the welding nipple diameter to a minimum which reduces the "Swiss Cheese Perforation Effect" on headers and spray rings especially with small nozzle pitches.

The solution – MicroSCALEMASTER®

The **MicroSCALEMASTER®** outer welding nipple diameter of only 16 mm (Standard-SCALEMASTER® 43,5 mm, MiniSCALEMASTER® 27 mm)

allows complicated spray ring designs. It also helps to reduce the header pipe wall thickness for flat product descaling in thin slab rolling mills. This is a remarkable cost saving factor especially at pressures beyond 300 bars.



Standard SCALEMASTER®

MiniSCALEMASTER®

MicroSCALEMASTER®

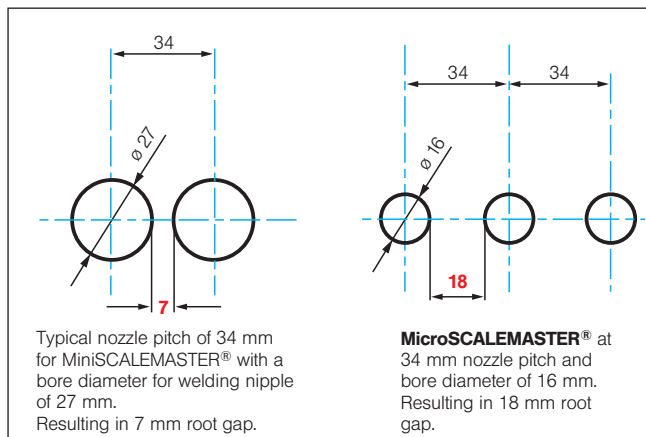

Comparison of MiniSCALEMASTER® and MicroSCALEMASTER®: Typical arrangement

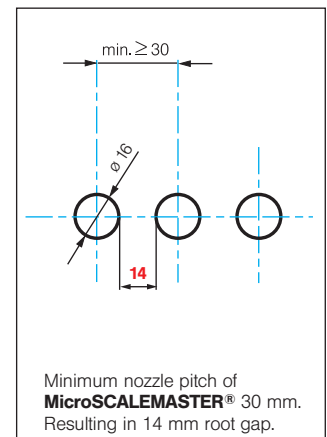

MicroSCALEMASTER® minimum nozzle pitch

MicroSCALEMASTER®

Flow Rate Chart

Ordering Data

Spray angle α	Ordering No.		A \emptyset [mm]	E \emptyset [mm]	Flow rate for water (\dot{V})					
	Type	Mat.-No. 27 Tungsten carbide			p = 100 bar (1450 psi)		p = 200 bar (2900 psi)		p = 400 bar (5800 psi)	
					[l/min]	[US Gall./min]	[l/min]	[US Gall./min]	[l/min]	[US Gall./min]
22°	622.495	○	1,2	1,5	12,00	3,17	16,97	4,50	24,00	6,34
	622.535	○	1,4	1,8	15,00	3,96	21,21	5,60	30,00	7,92
	622.565	○	1,8	2,0	18,00	4,76	25,46	6,73	36,00	9,52
	622.605	○	1,8	2,1	23,00	6,08	35,53	9,39	46,00	12,16
	622.645	○	2,0	2,5	28,00	7,40	39,60	10,46	56,00	14,80
26°	622.496	○	1,5	1,17	12,00	3,17	16,97	4,50	24,00	6,34
	622.536	○	1,75	1,3	15,00	3,96	21,21	5,60	30,00	7,92
	622.566	○	2,0	1,5	18,00	4,76	25,46	6,73	36,00	9,52
	622.606	○	2,1	1,7	23,00	6,08	35,53	9,39	46,00	12,16
	622.646	○	2,5	1,9	28,00	7,40	39,60	10,46	56,00	14,80
30°	622.497	○	1,5	1,16	12,00	3,17	16,97	4,50	24,00	6,34
	622.537	○	1,75	1,3	15,00	3,96	21,21	5,60	30,00	7,92
	622.567	○	2,0	1,4	18,00	4,76	25,46	6,73	36,00	9,52
	622.607	○	2,1	1,6	23,00	6,08	35,53	9,39	46,00	12,16
	622.647	○	2,5	1,8	28,00	7,40	39,60	10,46	56,00	14,80
40°	622.498	○	1,5	1,11	12,00	3,17	16,97	4,50	24,00	6,34
	622.538	○	1,75	1,2	15,00	3,96	21,21	5,60	30,00	7,92
	622.568	○	2,0	1,2	18,00	4,76	25,46	6,73	36,00	9,52
	622.608	○	2,1	1,5	23,00	6,08	35,53	9,39	46,00	12,16
	622.648	○	2,5	1,6	28,00	7,40	39,60	10,46	56,00	14,80

Volume rate conversion formula:

$$\dot{V}_2 = \sqrt{\frac{p_2}{p_1}} * \dot{V}_1 \text{ [l/min]}$$

$$p_2 = \left(\frac{\dot{V}_2}{\dot{V}_1} \right)^2 * p_1 \text{ [bar]}$$

How to order:

Type + Mat.-No. = Ordering No.
622.495 + 27 = 622.495.27

A = equivalent bore diameter · E = narrowest free cross section



MicroSCALEMASTER® arrangement on a header

MicroSCALEMASTER® Components Ordering Data



Lechler GmbH
Precision Nozzles - Nozzle Systems
P.O. Box 13 23
72544 Metzingen / Germany
Phone: +49 (0) 71 23 962-0
Fax: +49 (0) 71 23 962-333

E-Mail: info@lechler.de
Internet: www.lechler.de



MicroSCALEMASTER®
assembled

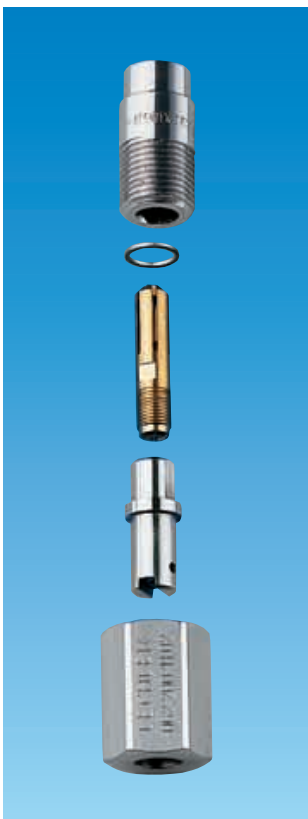

MicroSCALEMASTER®
components

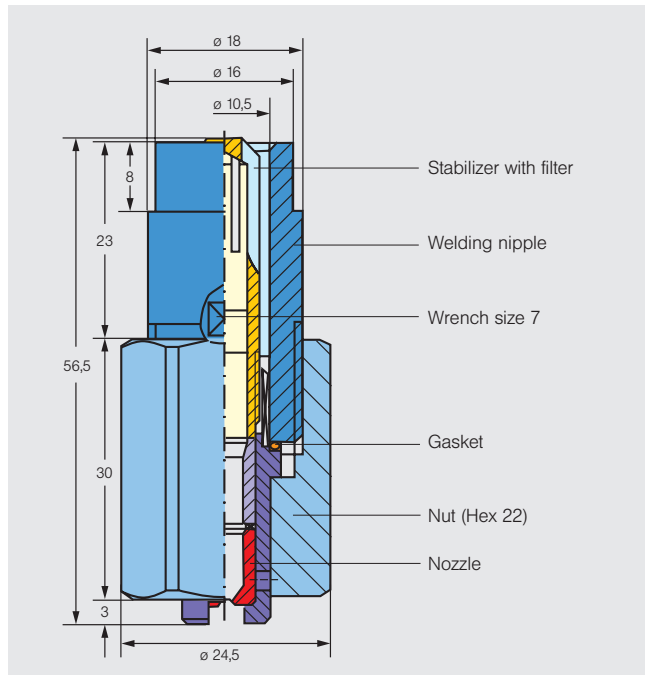

Component		Ordering No.	Weight [kg]
Welding nipple Material: AISI 304	Length: L = 35 mm	062.210.17.02	0,040
Stabilizer with filter Material: Brass	Length: L = 35 mm	062.250.30	0,007
Gasket Material: AISI 304		095.015.1C.07.08.0	
Nozzle		622.XXX.27 (see table)	0,015
Nut Material: AISI 431	Hex 22	062.200.11.02	0,059
Alignment tip Material: Mild steel	Data sheet on request	062.290.01	0,020
Tip extractor	Data sheet on request	095.009.00.13.77.0	1,200

Nipple welding

To guarantee the correct alignment of the nozzle tip (15 degree offset), the welding nipple must be positioned on the spray header such that the flats on the tip are parallel to the header longitudinal axis. We recommend you do this with our alignment tip. It ensures proper positioning of the nipple during welding.



Alignment tip

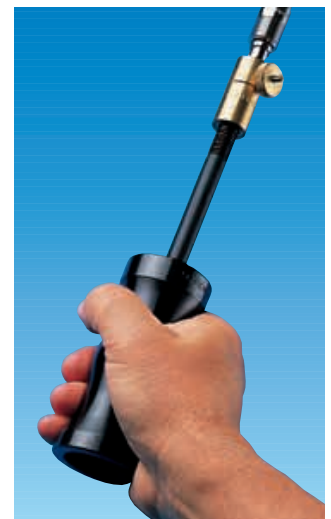

Tip extractor

Belgium: Lechler S.A./N.V. · Avenue Mercatorlaan, 6 · 1300 Wavre · Phone: (10) 225022 · Fax: (10) 243901 · info@lechler.be
China: Lechler Intl. Trad. Co., Ltd. · Beijing Office · Rm.1812 CTS Plaza · No.2 Bei San Huan Dong Lu · Phone: (86) 1064661986, Fax: (86) 1064660196 · info@lechler.com.cn
Finland: Lechler Oy · Kalliotie 2 · 04360 Tuusula · Phone: (358) 98709844 · Fax: (358) 98709847 · info@lechler.fi
France: Lechler France, S.A. · Bât. CAP2 B51 · 66-72, Rue Marceau · 93558 Montreuil cedex · Phone: (1) 49882609 · Fax: (1) 49882609 · info@lechler.fr
Great Britain: Lechler Ltd. · 1 Fell Street, Newhall · Sheffield, S9 2TP · Phone: (0114) 2492020 · Fax: (0114) 2493600 · info@lechler.com
India: Lechler (India) Pvt. Ltd. · Plot B-2 · Main Road · Wagle Industrial Estate · Thane (W) · 400604 · Phone: (22) 25811196 · Fax: (22) 25821262 · lechler@lechlerindia.com
Sweden: Lechler AB · Box 158 · 68324 Hagfors · Phone: (46) 56325570 · Fax: (46) 56325571 · info@lechler.se
Spain: Lechler S.A. · Avda. Pirineos 7 · Oficina B7, Edificio Inbisa I · 28700 San Sebastián de los Reyes, Madrid · Phone: (34) 916586346 · Fax: (34) 916586347 · info@lechler.es
USA: Lechler Inc. · 445 Kautz Road · St. Charles, IL 60174 · Phone: (630) 377-6611 · Fax: (630) 377-6657 · GeneralMgr@lechlerUSA.com