

## **Successful Execution of Roll Cooling Strategies**

By Bernard J. Forster, Business Manager, Metallurgical Division,  
Lechler, Inc., St. Charles, Illinois

### **INTRODUCTION**

In today's hot rolling mill, realizing the promised longevity of high speed steel rolls depends on one's ability to develop successful roll cooling strategies that successfully manage heat transfer issues. Moreover, effective cooling in both hot and cold rolling mills has proven ever more critical to today's standards of product quality and the ability to affect product shape and eliminate surface defects.

However, in practice, the pursuit of "perfection" in hopes of realizing ideal Heat Transfer Coefficients inevitably runs up against the law of diminishing returns. The purpose of this paper is to review rolling mill cooling concepts, to examine the real world limits on returns-on-investment in rolling mill cooling system designs and to discuss the implications of these findings for optimizing rolling mill cooling spray delivery systems in hot and cold rolling mills of various types.

### **PRINCIPLES OF COOLANT APPLICATION**

First, we will review the underlying concepts that affect cooling system design.

Coolant is used for multiple reasons: 1) to cool rolls; 2) to provide lubrication (in cold mills); 3) to control product temperatures (for example in inter-stand cooling stations in hot mills); and 4) to control the thermal profile (in most cold sheet mills, many other cold mills, and increasingly even in hot mills).

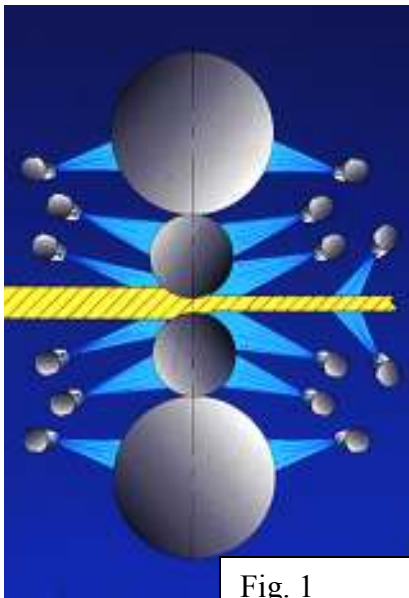

Fig. 1

One of the first questions in cooling strategy development is where to apply the coolant. Often, some suggest that the answer to this question is to apply coolant at the roll bite. Others further argue that for an "ideal" cooling situation, one would also apply coolant on the work roll itself, with some adding that the most effective cooling occurs when coolant is also applied to the backup rolls. The pursuit of the theoretically ideal cooling system would further argue that if you are cooling the top rolls in this manner, the same should be done for the bottom rolls. What one would end up with is quite an expensive system (shown in Figure 1), which nonetheless can be functionally inadequate because even large quantities of sprayed water or coolant do not necessarily result in effective cooling, for a variety of reasons.

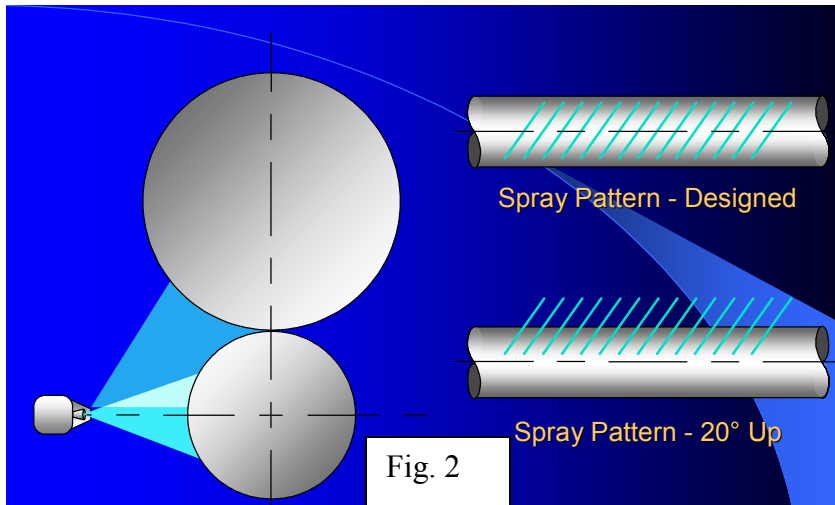
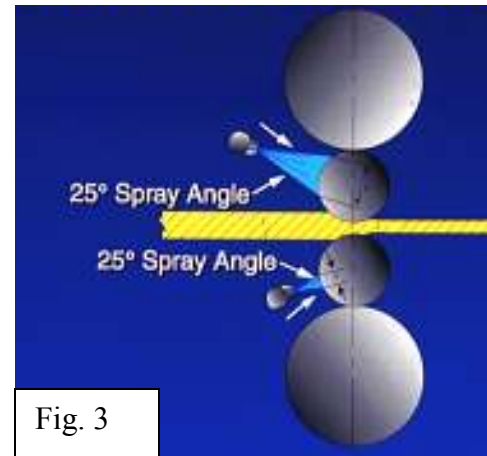

Figure 2 examples a header's position askew by 20 degrees, such that approximately half of the surface that was targeted in the cooling strategy is being missed.

Similarly, an unbalanced spray impact distribution between the top and bottom rolls (shown in Figure 3) will be created when the respective headers are positioned differently, resulting in unbalanced cooling between the top and bottom rolls.



Even when system designs have taken these factors into account, it is quite common for headers to get damaged in a manner that skews the way in which the spray impacts the roll surface, given the damage that mill cobbles wreak. Too often, repairs merely determine if header sprays are functioning and stop short of analyzing if headers are in the required orientation. Worse yet, responsible maintenance personnel may be ill-informed as to the exigencies of header orientation and think that 'there is no science to putting a header in place', opting instead to ensure that nozzles are tightly screwed into place, regardless of their orientation. Indeed, if the choice appears to be between tightly screwed nozzles or aligned nozzles, the common but mistaken choice is to opt for tightly secured nozzles. In fact, poor nozzle alignment is a highly significant contributor to sporadic and inconsistent roll cooling.

### COOLING SYSTEM DESIGN CONSIDERATIONS

The first principle of cooling system design is consideration of all heat sources (See Figure 4).

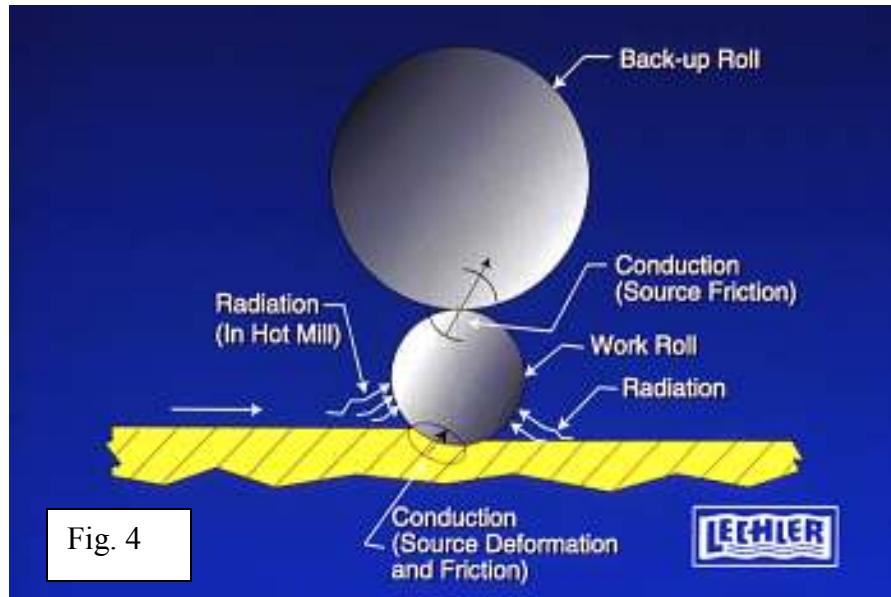

Fig. 4

Heat is primarily generated in the roll gap (roll bite) from deformation of the metal and friction, at the direct interface between the product and rolls. Heat energy is related to the actual electrical energy driving the mill stand. Some mechanical energy is consumed in increasing the hardness of the strip, but most (i.e. 85% of the total electrical energy driving the mill) will become heat that must be removed.

In the hot mill scenario, additional heat is generated from the product itself by radiation, and with a small percentage (usually less than 1%) at the contact points between the work rolls and the backup rolls.

As the roll moves away from the roll bite, heat is pulled into the roll interior. The rate of diffusion depends on the temperature differential between the surface and the core and the roll conductivity. The purpose of a spray system is to remove heat from the roll surface *before* this heat energy diffuses to the core. Thus, cooling systems must maintain a thermal balance between top and bottom rolls, as well as across the full width of the rolls, and do so as economically as possible.

In creating a spray cooling system design, the relevant parameters to consider answer the questions—

- What are the target surfaces?
- Which side of the mill should one be cooling?
- Where should headers be placed?

-What kinds of nozzles and roll spray patterns should be utilized?

-How should nozzles be spaced?

-What is the optimum number of rows to build?

What are the target surfaces?

There are four target surfaces that are generally considered: 1) the product surface; 2) the backup roll; 3) the work roll; and 4) the roll bite.

Product surface cooling is less frequently used in the cold mill, especially on the delivery side where dry surfaces are desired for coiling or stripping. The exceptions that prove this rule include the use of coolant as a back flush along the strip to prevent measuring instruments like x-ray gauges from giving false readings, and when the mill is running very wide, thin material at high speeds. Sometimes product surface cooling is also used in cold mills to inhibit carryover from one stand to another. This may be especially important in a tandem mill prior to the last stand if a cleaning solution rather than an oil emulsion or dispersion is used in the final stand. In Z-mills running stainless steel, it is important to actively cool stainless steel before it carries heat out of the mill. This is the case because the work roll contact area is small in this type of mill and the Heat Transfer Coefficient between stainless steel and the work roll is relatively low. If sufficient cooling is not done, product is likely to be discolored.

In hot mills, there may be several reasons why cooling of product surfaces becomes important. Achieving desired product metallurgical properties often requires product surface cooling. Hence, cooling may be used between finishing stands to help achieve the correct temperature of the sheet as it enters the runout table.

Many argue that the back up roll acts as a large heat sink, but in reality the contact line between the backup roll and the work roll has a small area.

Moreover, even if the backup roll picked up heat from the work roll, the reverse would occur, i.e. the work roll would then attract heat from the backup roll. This is nothing more or less than the first law of thermodynamics--- heat ALWAYS moves from the warmer to the cooler body (See Figure 5).

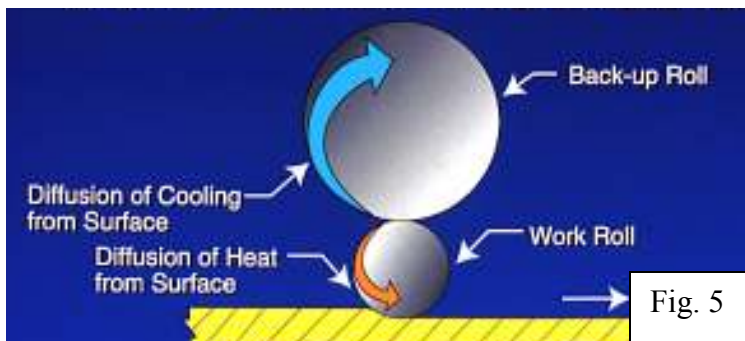

Thus, if one adequately cools the work roll, one automatically controls the temperature of the backup roll. Consequently, controlling cooling of the work roll usually becomes the first and most important point of address for the well-designed cooling system. Here too there are exceptions that prove the rule, which are typically mills where the backup rolls are the driven rolls. In this type of mill, the friction and heat generated by slippage as the backup roll tries to turn the work roll can be considerable, transferring heat directly into the backup roll.

Some consider spraying into the roll bite itself, which is typically problematic in that coolant sprayed into the roll bite cools the roll in a striped manner. In fact, when one is cooling the work roll an important consideration is the determination of which side of the work roll requires coolant, the entry or the exit side, or more to the point, how far away from the roll bite one needs to begin cooling the work roll. In a hot mill, coolant is not advisable near the roll bite due to the Leidenfrost

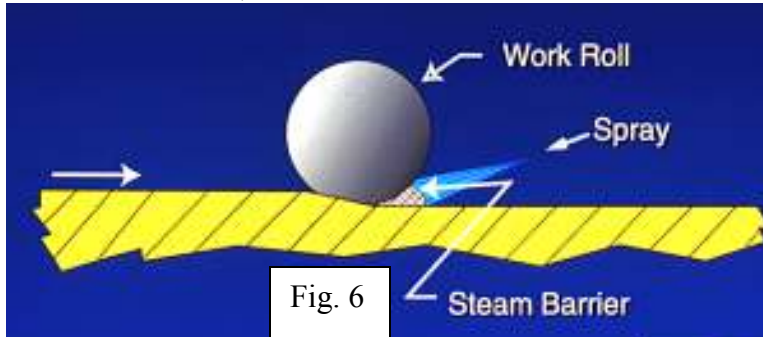

Effect, which is the creation of a steam barrier between the roll surface and the coolant, creating a very low heat transfer (shown in Figure 6). The more water you spray in, the more steam results, creating increasingly poor heat

transfer between the air and the work roll surface. It is much better to have air and radiation in the area adjacent to the roll bite because it is more efficient than using a coolant. This effect is also why wipers are important to hot mill function, in that they prevent water or coolant from getting into the roll bite.

Note: There are many hot mills that inject lubricant into the roll bite, which can cut the energy requirements for rolling up to 20%. This is not for cooling purposes per se, and here too the wiper quality is important to prevent water from coming down onto the roll surface.

The situation in the cold mill differs in regards to cooling the roll bite. In the cold

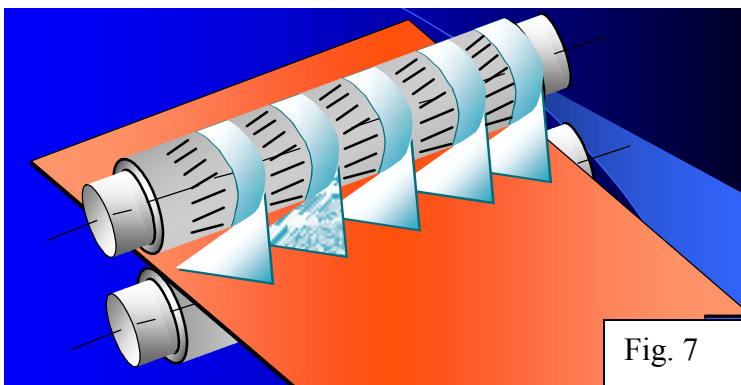

mill the lower temperatures are such that coolant can be applied as close to the roll bite as possible. It should be applied entirely on the roll or on the product. If the coolant is applied such that it bisects the roll bite, it cools both the roll and product in stripes as shown in Figure 7.

In summary, in most mills the primary surface to target is the work roll.

*Which side of the mill should one be cooling?*

The determination of which side of the mill to cool depends upon the overall mill design and cooling strategy.

In the typical hot mill, cooling is generally done on both sides for several reasons. First, the higher temperatures involved require more cooling. Secondly, the aforementioned Leidenfrost Effect and the necessity to keep coolant out of the roll bite area is an inherent limit that can be counterbalanced by cooling on both the entry and exit sides. Third, unlike in the typical cold mill design, there is no instrumentation between the mill stand and the coolant that would otherwise interfere, making cooling on both sides possible. Additionally, in hot mills there is no product staining issue.

In a tandem cold mill, one generally only applies coolant on the entry side in order to avoid trapping water in the strip prior to coiling and thereby creating conditions for staining. Also, one would not apply coolant to stands in which there is instrumentation, especially x-ray gauges, to avoid coolant affecting instrument readings.

In a reversing cold mill, coolant is applied on both sides but only on the entry point in the direction in which the rolling is being done. This is achieved by turning one set of spray system headers off.

*Where should headers be placed?*

Because header location is often left as a secondary consideration to overall mill design, the positioning of headers is typically dictated by the space constraints and the need to accommodate other mill equipment. Even though headers are fit

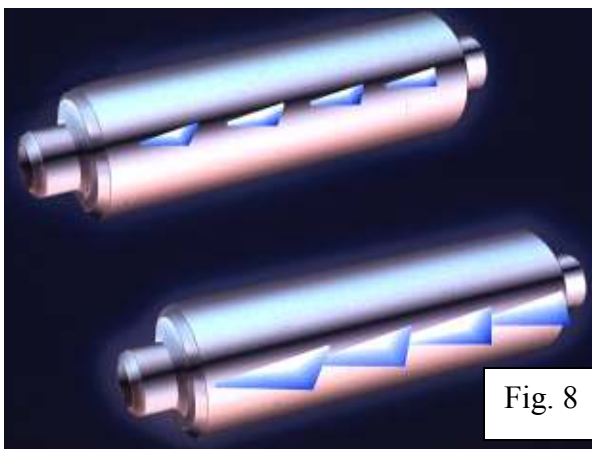

in as they can be, it is nonetheless important to determine their precise location, as this in turn will determine the types of sprays to be used. For example, if one has headers on the top roll that are 10 inches from the roll surface and headers on the bottom roll that are 20 inches from the roll surface, the use of the same sprays will NOT result in even coverage, and therefore adjustments need to be made accordingly, as shown in Figure 8.

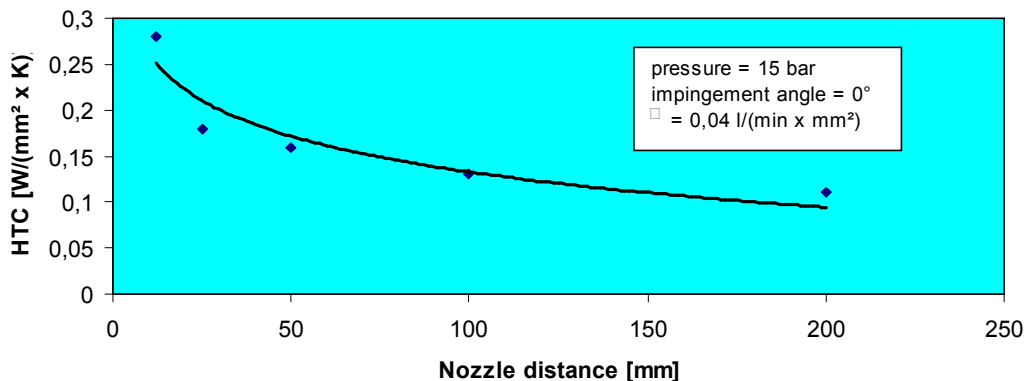

Fig. 9

Figure 9 shows the Heat Transfer Coefficient as a function of spray distance, and illustrates the general principle that the law of diminishing returns compromises the ability to achieve “perfection” in a spray system. While the graph clearly shows that heat transfer is improved by reducing the distance from the surface, there are practical limits to consider. First, there is the need to get rolls in and out of the mill. One needs to consider that the actions of threading the roll can lead to header damage as you move it in and out, if adequate clearance has not been appropriately calculated. Second, one does not want to locate the headers so close that there is no room for a coolant exit path. Typically this requires a minimum space of about 75 mm (or 3 inches). The Heat Transfer Coefficient is not markedly affected by moving back this distance. Third, one must consider the ability for mounting stability in a given location. If the headers are not firmly fixed in position, the header can shift or rotate resulting in ineffective spray coverage on the rolls.

As Figure 9 illustrates, the Heat Transfer Coefficient is actually quite forgiving in terms of header location. Thus, while one might argue that the ideal system places headers as close to the rolls as possible, real world constraints suggest that a successful balancing act of all considerations leads to a better overall system. Practically speaking, the unique design of each mill has great bearing on the space availability for header locations. Cobble guards, instruments, roll change gear, guide boxes and their movement, and other equipment leave limited space available for headers. Ideally, it is desirable to have the top and bottom headers located identically relative to the respective work rolls, with internal passageways large enough to meet coolant velocity requirements, and in fixed positions that prevent movement and displacement of nozzles, as well as sufficient protection of nozzle tips to prevent “heads” and “tails” from damaging the nozzles.

What kinds of nozzles and roll spray patterns should be utilized?

To successfully implement the cooling strategy, several variables that affect the Heat Transfer Coefficient are balanced to determine the most effective spray footprints to use.

Two types of nozzles—flat spray and full cone—have been extensively studied and used. Figure 10 shows the basic design difference between these two types of nozzles.

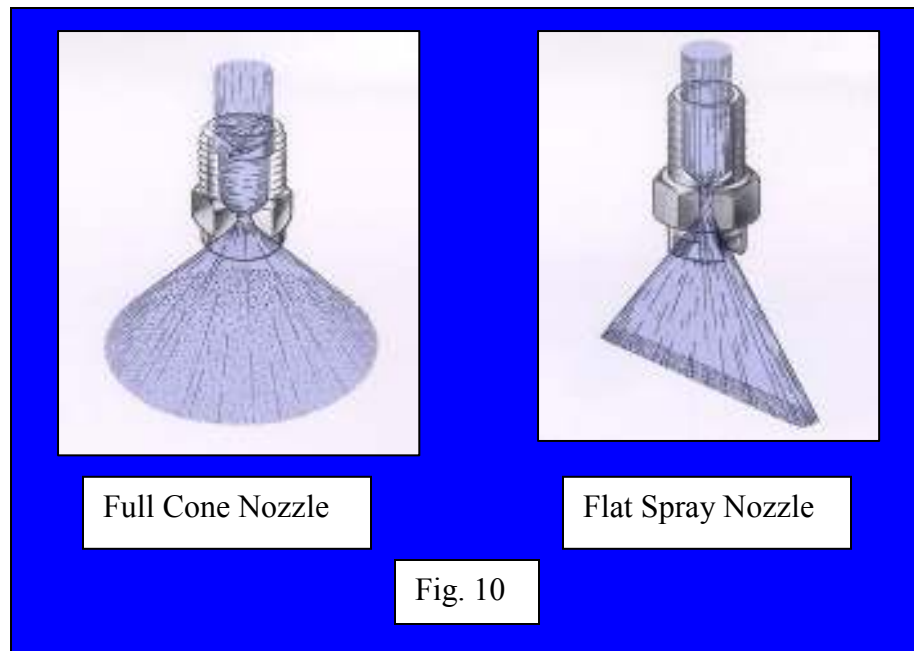

The superior cooling with flat fan nozzles for equivalent pressures and flow rates has been extensively studied and reported.<sup>1</sup> This documented superiority of flat spray nozzles can be attributed to several factors: 1) Full cone nozzles are more likely to plug in operation because their design features complex, internal passages that are clog prone; 2) Neighboring flat spray nozzles can be offset to allow for overlapping coverage zones without interference between spray patterns. In contrast, the circular pattern of full cone nozzles creates overlapping zones where airborne droplets from one spray collide with droplets from

---

<sup>1</sup> M. Raudensky, L. Bendig, J. Horsky, “Experimental Study of Heat Transfer in Process of Rolls Cooling in Rolling Mills by Water Jets”, Research Paper.

neighboring sprays, resulting in striped overlapping zones as shown in Figure 11;

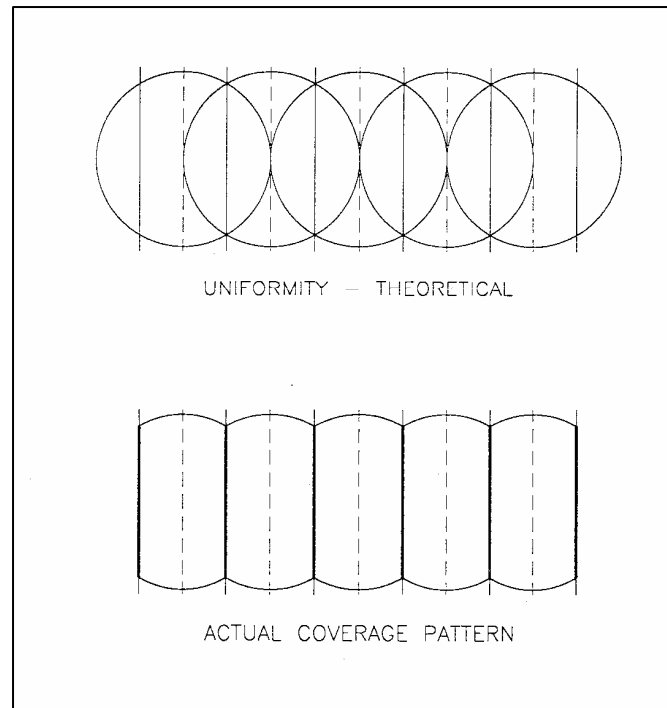

Fig. 11

- 3) Full cone nozzles spray angles are affected more by liquid pressure changes;
- 4) Header locations often require special full cone nozzles, whereas standard flat spray nozzles can be configured effectively for nearly every standoff distance;
- and 5) Flat spray nozzles are less expensive than full cone nozzles.

The footprint of the flat spray nozzle on the roll is especially critical to effective heat transfer, and requires consideration of the underlying mechanics involved in successful heat transfer. Heat transfer to the coolant is dependent on dwell time of the coolant on the roll, which is brief given the tangential forces acting on them. In hot mills, coolant is converted into steam creating a steam barrier that diminishes this dwell time. Thus, determining the best heat transfer for the maximum stand-off distance between the work roll and the header helps in selecting the appropriate nozzle. Nozzles with narrow spray angles generally give the best results in hot mills because they deliver a higher impact density for a given flow rate and pressure compared to wider angle nozzles. In cold mills spray angles are selected that maximize the impact area on the work roll.

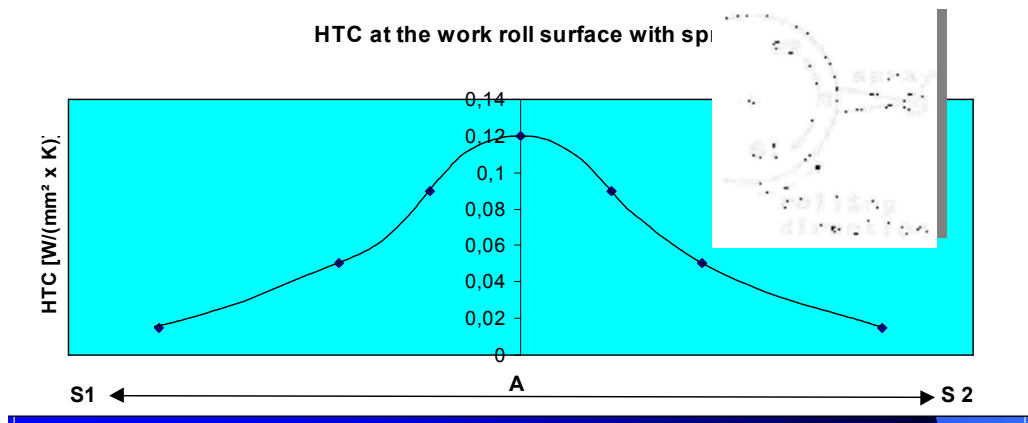

Fig. 12

Figure 12 illustrates the Heat Transfer Coefficient as a function of the flat spray nozzle inclination angle. Experiments show that sprays applied as close as possible to 90° from the roll surface yield the most effective Heat Transfer Coefficient. Such right angle orientation is not always possible, but it is the “ideal”.

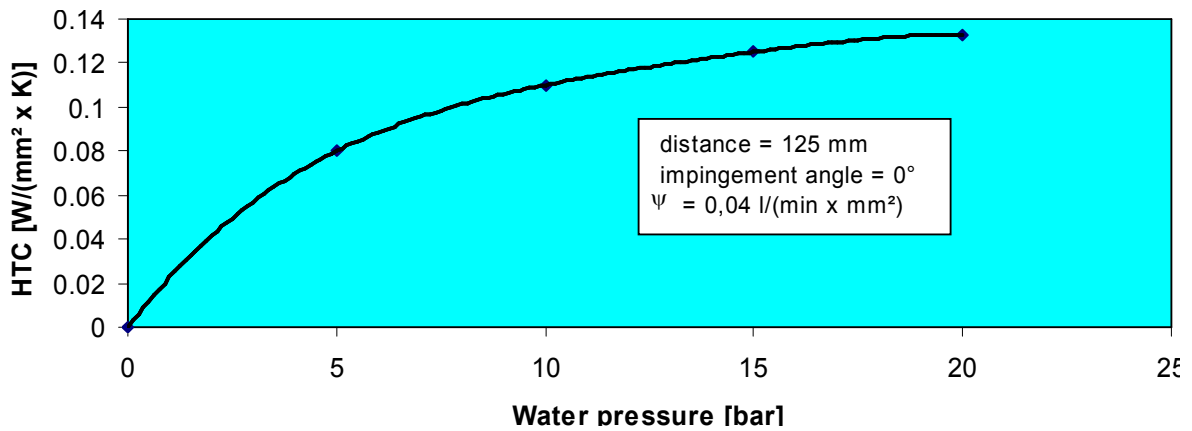
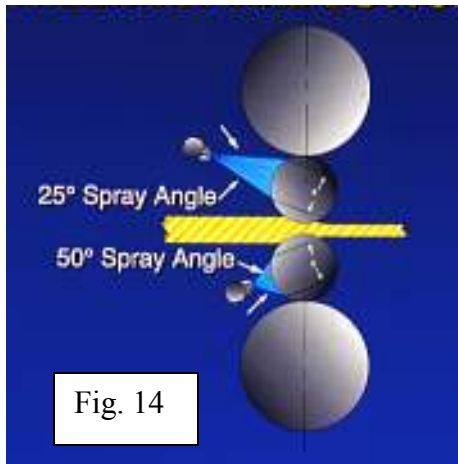

Fig. 13

Figure 13 illustrates the Heat Transfer Coefficient as a function of water pressure. As one can see from this graph, the higher the pressure, the higher the Heat Transfer Coefficient. But here too the law of diminishing returns comes into play, despite the popular misconception that higher pressure is always superior. Above 10 bar (140 psi), there is minimal gain in the Heat Transfer Coefficient, but there would be a good deal of pumping (and related energy) to achieve these greater pressures. These higher pressures translate into wasted dollars for larger motors, pumps, and their operating costs. On the other hand, falling below 6 – 7 bar (85 PSI) DOES significantly and negatively impact the

Heat Transfer Coefficient. Thus, the “sweet spot” is in the range of 7 - 10 BAR (100 – 150 PSI).



In nozzle selection, one must create a balanced spray impact distribution between the top and bottom rolls, even when the spray angles vary, as exemplified in Figure 14. Once the footprint has been established for the header for the maximum stand-off distance from the roll, a spray angle that will match the footprint on the opposite roll is chosen for nozzles in the corresponding header. Nozzle spray angles are selected that provide the best results under both maximum and minimum roll diameter conditions.

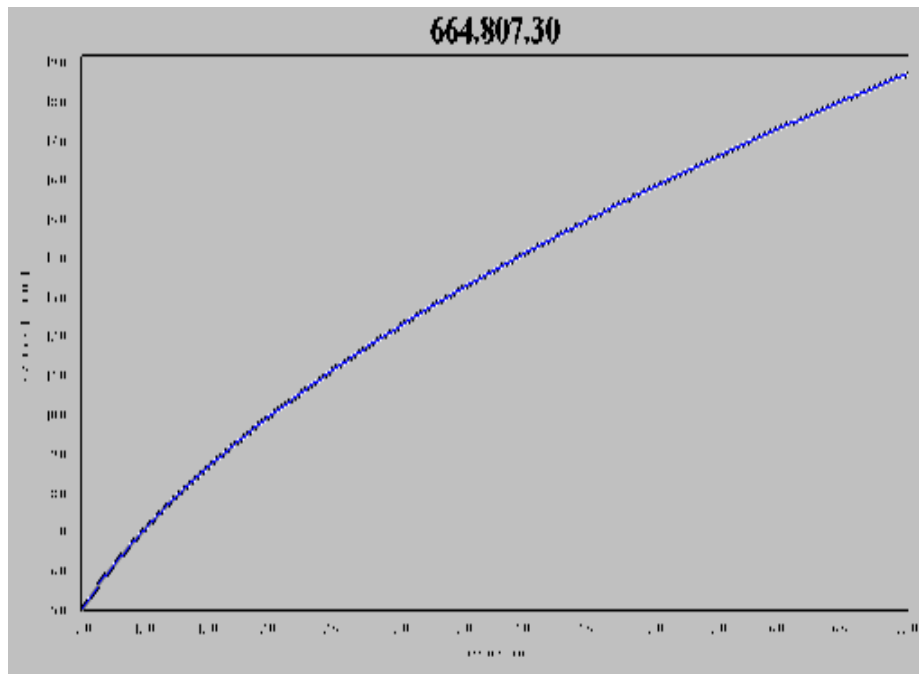

Fig. 15

Figure 15 shows a Typical Pressure/Flow Rate diagram for the flat jet nozzle. The higher the pressure, the higher the flow. Doubling the flow requires a four-fold increase in the pressure.

Whether or not a pre-existing coolant system exists that defines the total flow and pressure available at the header, shapes the process used for nozzle selection. When a header’s distance from the roll is pre-defined, the correct nozzle to

obtain the desired impact density can be selected for each roll. If sufficient flow and pressure exist, nozzle selection to achieve target densities can be optimized.

When there is no pre-existing coolant system, ideal nozzles can be selected, the desired flow, pressures and velocities in the header can be calculated, the piping can be sized based on the needs of the header, and the pumps can be sized based on header requirements plus losses in the piping. Ancillary equipment such as filters and valves can similarly be specified based on the needs of a defined system, ensuring the most rational investments in the best possible system designs.

Figure 16 depicts the heat transfer properties of square, oval, and flat jet nozzles in a typical fluid pressure.

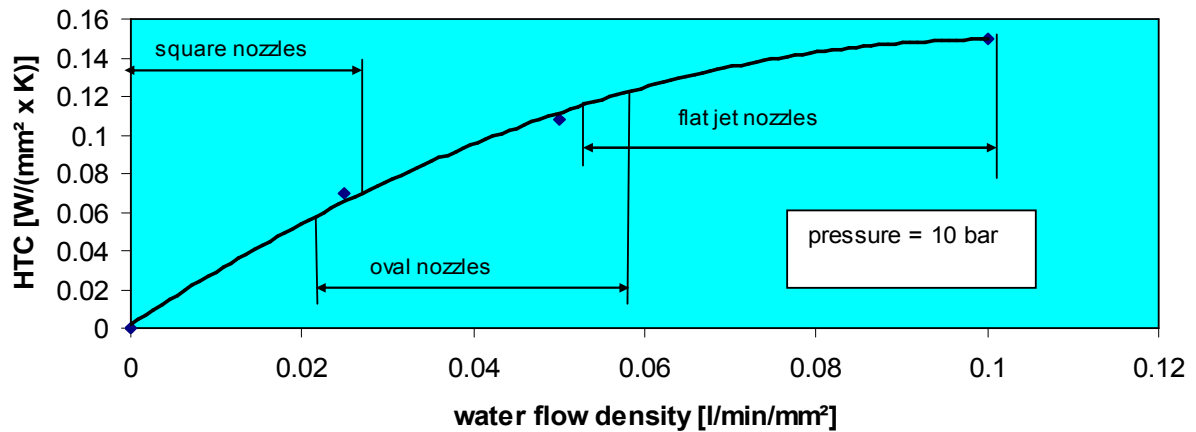

Fig. 16

How should nozzles be spaced?

The ideal spray is stable, defined, uniform and precise such that all the benefits of tightly controlled thermal management can be realized.

If a spray is not stable it will not provide sufficient heat transfer. A spray that is breaking up might give a lot of water to the roll with only a fraction of it doing considerable work in terms of heat removal. Uniformity is important to allow for an even distribution, and therefore nozzle spacing is key.

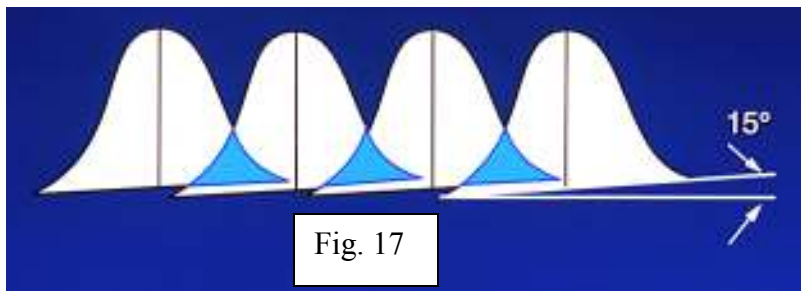

Fig. 17

Flat fan nozzles can have either an even distribution, which spreads liquid evenly across the full width of the nozzle footprint, or

a parabolic distribution nozzle that has a heavier concentration of liquid at the center. As shown in Figure 17, parabolic distribution nozzles provide the ability to overlap on a header in a way that yields uniform distribution. Even distribution nozzles are very difficult to overlap in a header in a way that will yield uniform distribution over the entire width and for this reason are very unforgiving, meaning that even slight conditions that deviate from ideals will cause problems.

The most sophisticated and dependable header designs are now created with simulation software that models distribution and ensures appropriate configuration of header designs. In nearly all cases, specialized flat fans with self-aligning features are the optimum header designs, which eliminate possibilities of improper aiming that will cause disruption in the required overlaps compromising uniformity, as shown in Figure 18.

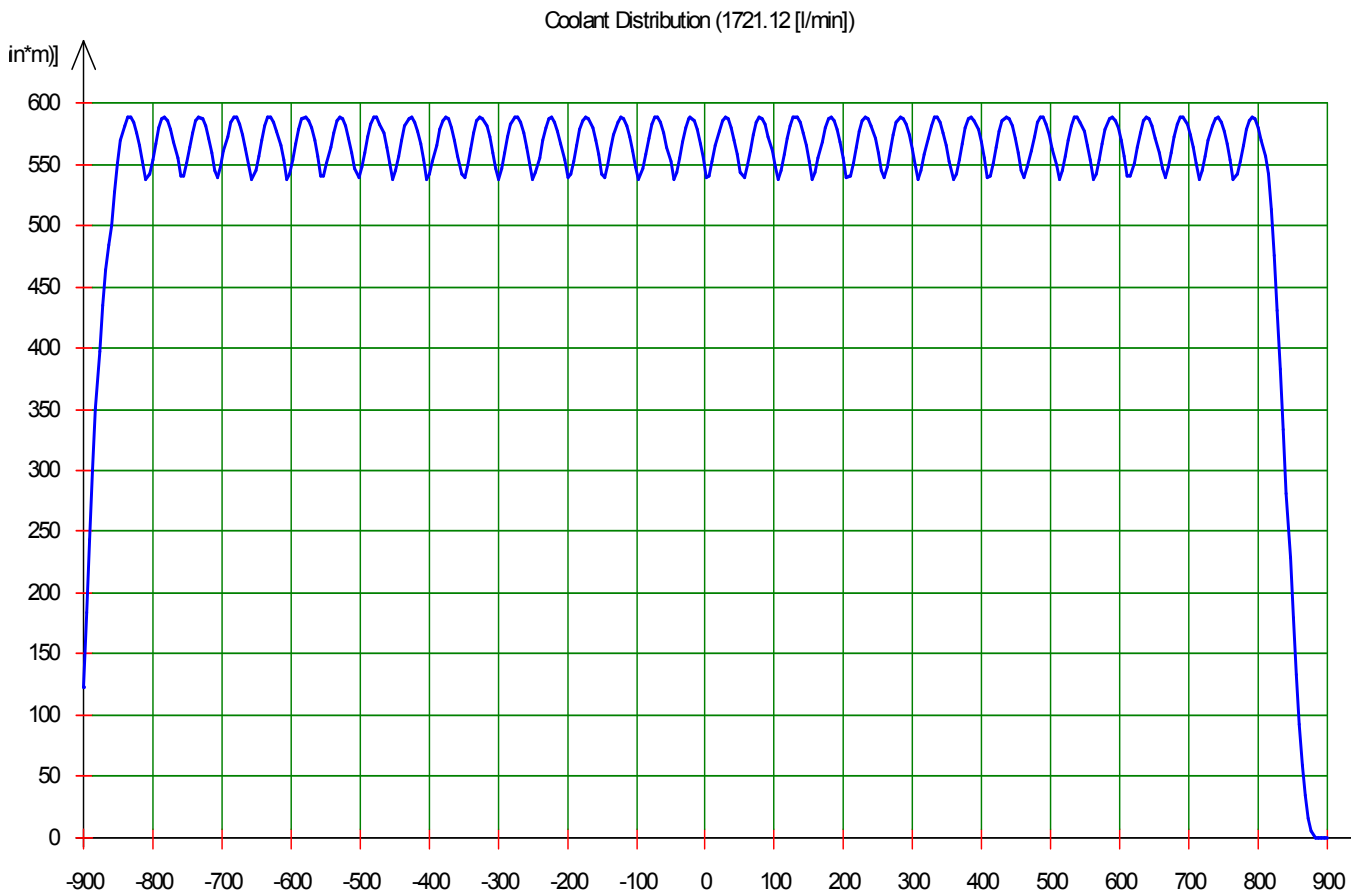

Fig. 18

*What is the optimum number of rows to build?*

As in other examples noted above, chasing the “ideal” number of rows is less relevant than seeking optimized, practical solutions that take into account the underlying thermal and other physical forces at work.

Typically, two rows of nozzles are recommended such that the chances for running a dry spot on the roll are minimized. One might ask why additional rows are not recommended in order to further minimize the chances of dry spots. Considering that each additional row requires a narrowing of orifices and increases chances for plugs, the rule of thumb experience that two rows are the optimized design is relied upon.

In the hot mill, however, three rows are sometimes recommended in order to maximize the heat transfer optimum that occurs when spray impacts the roll in a perpendicular manner. Thus, the additional row enables one to reduce spray angles closer to this ideal and consequently optimize the heat transfer.

## **SUMMARY**

Engineered coolant application is a precision process to control the thermal profile of rolls effectively and efficiently with numerous cost-reduction benefits, including: improved roll life (especially the newer high speed steel rolls); reduced coolant consumption; fewer reject coils; controlled roll crown; faster setup and process control; downtime reduction; lower energy costs; and cleaner strip and mill.

While the basic laws of thermodynamics impact every aspect of cooling strategy design, executing successful roll cooling strategies typically depends on knowing how to optimize system details in ways that give the best return on invested engineering dollars. On the one hand, chasing the “ideal” system runs into the laws of diminishing returns. At the same time, ignoring the relevant design details that significantly impact cooling system function will compromise both hot and cold rolling mills’ abilities to create the high quality products that today’s market requires, significantly adding to the costs of production, or both.

## BIBLIOGRAPHY

1. L. Bendig, M. Raudensky, J. Horský, "Spray Parameters and Heat Transfer Coefficients of Spray Nozzles for Continuous Casting", 78th Steelmaking, 54th Ironmaking, and 13th Process Technology Conferences, Nashville, TN, USA, April 2-5, 1995
2. G. Downey, "Selective Differential Roll Cooling In Relation To Strip Flatness & Shape Control", International Conference on the Control of Profile and Flatness, Birmingham, England, March 25-27, 1996
3. B. Forster, "Coolant Application Concepts For Rolling Mills", 1995 AISE Iron and Steel Exposition and Annual Convention, Pittsburgh, PA, USA, September 25-28, 1995
4. D. R. Hill and L. E. Gray: Iron and Steel Engineer, 1981, Vol. 58, pp 51-62
5. T. J. Knox, "Development and Operation of Automatic Flatness Control", Advances in Cold Rolling Technology Conference, London, UK, Sept., 1985
6. E. A. Mizikar: Iron and Steel Engineer year book, pp 299-306; 1970, Pittsburgh, PA, Association of Iron and Steel Engineers
7. M. Raudensky, L. Bendig, J. Horský, "Experimental Study of Heat Transfer in Process of Rolls Cooling in Rolling Mills by Water Jets", Research Paper
8. P. D. Spooner, I. R. McDonald and G. F. Bryant, "Control of Strip Shape", Advances in Cold Rolling Technology Conference, London, UK, Sept., 1985
9. K. Tani, S. Ito, S. Ban, Y Kigawa, A. Mizuta, I Kokubo, and A. Teramoto, "Installation of 6-High Cold Rolling Mill With Roll Coolant Devices and Their Performance", Advances in Cold Rolling Technology Conference, London, UK, Sept., 1985
10. K. Tani, A. Mizuta, S. Ito, Y. Naito, K. Nawama, S. Ban, I. Kokubo, "Shape Control by Roll Coolant in a Tandem Cold-Rolling Mill", Advanced Technology of Plasticity, 1984, Vol. II, pp 1384-1392
11. K. Togai, "An Application of Advanced Control Theory on Shape Control for Thin Strip Rolling", IFAC Automation in Mining, Mineral and Metal Processing, Tokyo, Japan 1986
12. W. Y. D. Yuen, "Effective Cooling of Work Rolls in Strip Rolling", Materials Science and Technology, Vol. 4, pp. 628-634, July, 1988
13. W. Y. D. Yuen, C. H. Ellen, and I. A. Proctor, "Thermal Effects in Cold Rolling", Advances in Cold Rolling Technology Conference, London, UK, Sept., 1985